



# Unrivaled driv

ARC-X OWNERS MANUAL '08-'10

**YETI CYCLES**

600 Corporate Circle, Unit D  
Golden, CO  
USA  
P//303.278.6909 // 888.576.9384  
[www.yeticycles.com](http://www.yeticycles.com)

# Table of Contents

---

Brand Overview	6
Frame Features	8
Geometry	10
Maintenance Schedule	12
Bike Setup	
– Cable Setup	14
Warranty	16
Contact Information	17

# Overview

## WELCOME TO THE TRIBE

Congratulations on your purchase of a new Yeti bicycle and welcome to the Yeti Tribe. We are confident your new bicycle will exceed your expectations for value, performance and ride quality. Each frameset and component has been custom specified and designed to enhance your riding experience. Whether you are a beginner cyclist or a seasoned-pro, Yeti bicycles will provide endless hours of two-wheeled fun.

## GENERAL INFORMATION

This model-specific manual is designed to be used in conjunction with the general Yeti Owner's Manual and the manuals supplied by the suspension manufacturers. If you did not receive the Yeti Owner's Manual or the manual provided by the suspension manufacturer, download the materials off the Internet, or contact your dealer.

Bicycling can be a hazardous activity even under the best of circumstances. Proper maintenance of your bicycle is your responsibility and when done properly helps reduce the risk of injury and damage to your bicycle. This manual outlines basic setup and maintenance recommendations of your new Yeti. Because it is impossible to anticipate every situation or condition that may occur during the assembly, setup and maintenance of your bicycle, Yeti recommends that all service and repairs be performed by an authorized Yeti dealer.

This manual contains many "Warnings" and "Cautions" concerning the consequences of failure to maintain or inspect your bicycle. The combination of the safety alert symbol and the word "Warning" indicates a potentially hazardous situation in which, if not avoided, could result in serious injury or death. The combination of the safety alert symbol and the word "Caution" indicates a potentially hazardous situation in which, if not avoided, may result in minor injuries or damage to your bicycle or a component of your bicycle. Be sure to read and understand all "Warnings" and "Cautions".



**Warning:** Make sure you review and understand the warnings, instructions and content of this manual and accompanying manuals for your bicycle.



**Warning:** Technological advances have made bicycles and bicycle components more complex and the pace of innovation is increasing. It is impossible for this manual or accompanying manuals to provide all the information required to properly repair and maintain your bicycle. In order to help minimize the chances of injury, it is critical for you to have work performed by an authorized Yeti dealer.



## Frame Features

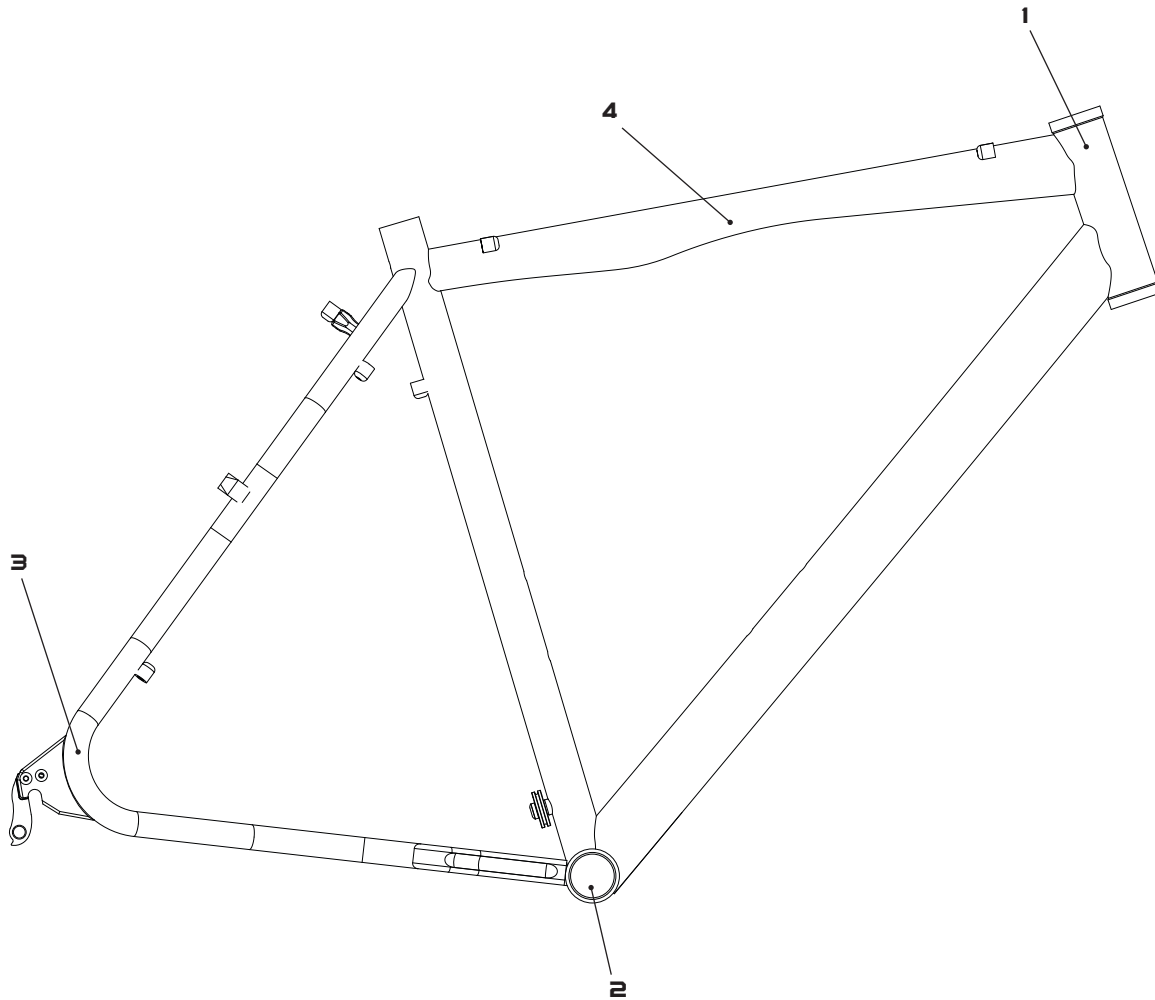

1. **PURE TUBING**

Yeti pure tubing is custom butted and tapered 7005 aluminum. This makes the frame lightweight and strong without the use of gussets. Unique shape provides added strength at the head tube junctions.

2. **BOTTOM BRACKET**

68mm shell.

3. **LOOPSTAYS**

Circular loops stays provide a singular loop for the rear triangle providing added stiffness and a sleek aesthetics.

4. **TOPTUBE**

Ergonomic top tube allows for easy shouldering for cyclo-cross riding

# Geometry

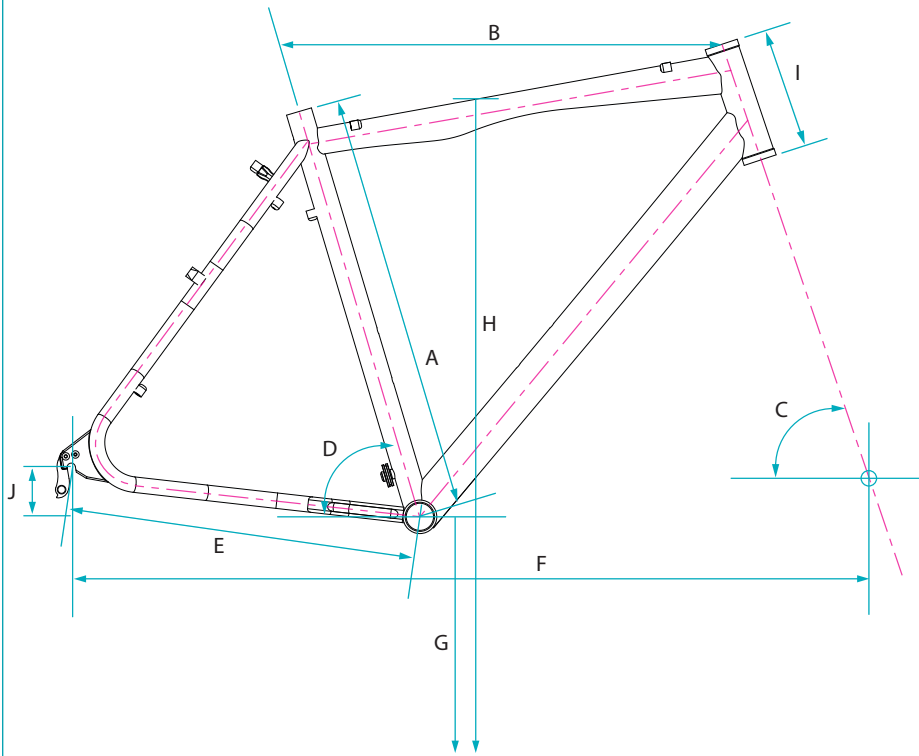

**GEOMETRY ARC-X**

	<b>SM</b>	<b>MD</b>	<b>LG</b>	<b>XL</b>
A	19.3	20.5	22	23.6
B	20.7	21.3	22	23.4
C	71	71.5	72	72.5
D	74	73.5	73	72.5
E	16.9	16.9	16.9	16.9
F	39.7	40	40.4	41.3
G	11.3	11.3	11.3	11.3
H	30.3	31.5	32.7	33.9
I	4.7	5.9	6.7	7.5
J	2.4	2.4	2.4	2.4

\*All measurements are in inches.

# Maintenance

**MAINTENANCE** Following these guidelines will help maintain the performance of your bicycle and prevent more serious problems from arising. It is important to remember that service intervals can vary depending on climate, trail conditions and riding frequency.

ACTION	WEEKLY	MONTHLY	3 MONTHS	ANNUALLY
Clean and lube chain	x			
Check tire pressure	x			
Clean bike of mud and debris (never spray water directly into frame or components)	x			
Check brake function	x			
Check shock pressure, if applicable	x			
Check for loose bolts and tighten, if necessary	x			
Check headset and tighten / loosen, if necessary		x		
Thoroughly clean pivot points with a rag (do not lubricate)		x		
Replace brake pads, if necessary			x	
Check tires for wear			x	
Check spoke tension and retention, if necessary			x	
Check chain for worn, damaged, or loose links, replace chain if necessary			x	
Complete tune-up performed by an authorized Yeti dealer				x



**MAINTENANCE?** Not sure how to work on your own bike? Contact your authorized Yeti dealer or visit [www.parktool.com](http://www.parktool.com) and check out the repair help section. This section contains detailed instruction on many of the service items listed in the maintenance schedule.

**TORQUE** We have attached a brief list of torque specifications for bolts and components that may need to be tightened while performing basic maintenance. This is just a guide. For specific torque, specifications, please contact the component manufacturer directly.

## TORQUE SPECS

Pivot Bolts	125 - 150
Derailleur Hanger Bolts	30 - 45
Handlebar Binder Bolt	150 - 180
Stem Binder Bolt	175 - 260
Seatpost Binder Bolt	150 - 180
Saddle Clamp Bolts	175 - 250
Rear Derailleur	70 - 86
Front Derailleur Clamp	45 - 60
Chainring Bolts	88 - 132



**Caution:** The torque specifications listed should be used as a guide when performing maintenance. Technological advances have made bicycles and bicycle components more complex, and the pace of innovation is increasing. Because of these advances, Yeti recommends that you refer to the torque specifications of the manufacture's component you are adjusting. In order to help minimize the chances of injury, do not perform any maintenance that you are no confident can be completed within your abilities.

## Cable Setup



**Caution:** The failure to properly route shifter housing can cause malfunction of the shift mechanism and unexpected shifting of gears.

**1 REAR DERAILLEUR** Take a piece of shifter housing and fit it from the rear shifter across the head tube into the outermost cable stop on the driveside of the top tube. The rear derailleur cable then runs along the top tube to the next cable stop located by the seat tube. Now fit a piece of housing from that derailleur cable stop to the one located on the inside of your driveside seatstay. Another piece of housing should now be fitted from the final cable stop on the seatstay to your rear derailleur. Now attach your rear derailleur cable and adjust.



**Tip:** You want your housing to run into the rear derailleur in as straight of a line as possible.

**2 FRONT DERAILLEUR** The second piece of rear derailleur housing runs into the outermost cable stop on the non-driveside of the top tube. The front derailleur cable then runs along the top tube to the outermost cable stop located on the non-driveside by the seat tube. Now fit a piece of housing from that derailleur cable stop into the cable stop located on the back of the seat tube. (Note: You should route the housing between the two seatstays above the bridge.) Now run your cable around the pulley wheel, located just above the bottom bracket of your frame. Now attach the cable to the derailleur and adjust for appropriate tension.



**3 REAR BRAKE** The rear brake loops across the head tube and fits into the middle cable stop located above the front derailleur cable stop. The rear brake cable runs along the top tube and into the middle cable stop located on the non-driveside of the frame at the seat tube. Now fit a piece of brake housing from the brake cable stop into the cable stop located on the bridge connecting the seatstays. Now run your brake cable to the rear brake caliper and adjust.

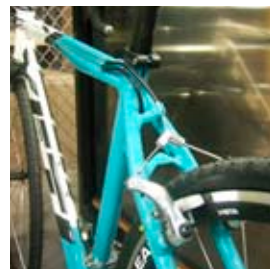

**HOUSING END CAPS** Yeti recommends using metal end caps to maintain the integrity of the housing. The metal caps do not allow the cable to pull through as do the plastic versions. Do not mix up the shift and brake housing because it will result in a loss in performance.

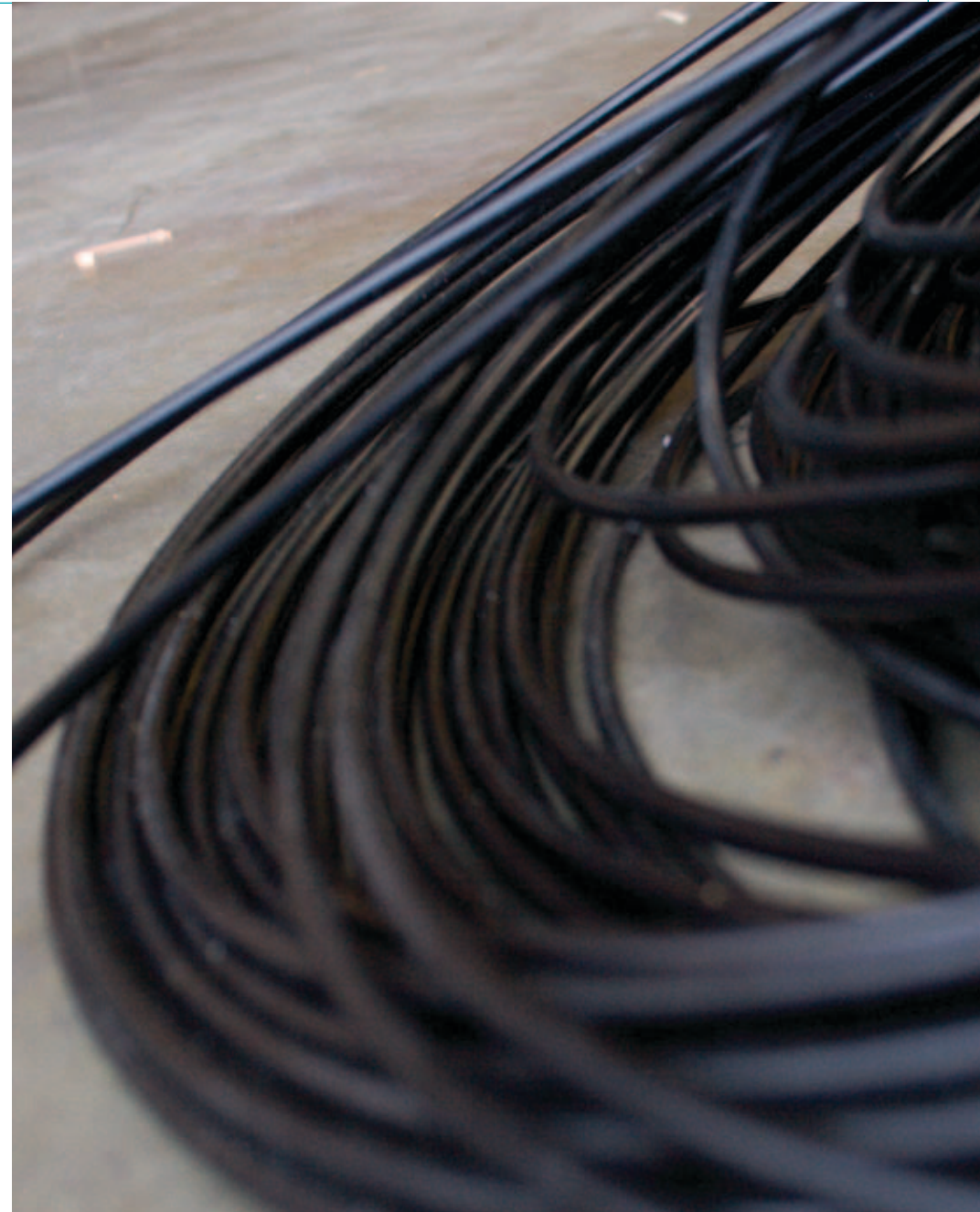

# Warranty

## **YETI LIMITED (2) TWO YEAR FRAME WARRANTY** (applies to 303, 4X, DJ)

Yeti Cycles will repair or replace, at its option, any frame it determines to be defective materials and / or workmanship. The (2) two year limited warranty is conditioned upon the bicycle being ridden under normal conditions and having been properly maintained. This warranty does not apply to the components attached to the frameset such as suspension components, wheels, drive train, brakes, seatpost, handlebar and stem. This warranty applies only to the original owner and is non-transferable. This warranty is void if the bicycle was not properly assembled by an authorized Yeti dealer.

## **YETI LIMITED (5) FIVE YEAR FRAME WARRANTY** (applies to AS-R sl, AS-R Carbon, 575, ARC, ARC-X)

Yeti Cycles will repair or replace, at its option, any frame it determines to be defective materials and / or workmanship. The (5) five year limited warranty is conditioned upon the bicycle being ridden under normal conditions and having been properly maintained. This warranty does not apply to the components attached to the frameset such as suspension components, wheels, drive train, brakes, seatpost, handlebar and stem. This warranty applies only to the original owner and is non-transferable. This warranty is void if the bicycle was not properly assembled by an authorized Yeti dealer.

## **ADDITIONAL CONDITIONS**

These limited warranties do not apply to normal wear and tear, nor to claimed defects, malfunction or failures that result from abuse, neglect, improper assembly, improper maintenance, alteration, collision, crash or misuse. The original owner shall pay all labor charges connected with the repair or removal of all components. Under no circumstances does this limited warranty include of the cost of travel or shipment to and from an authorized Yeti dealer. In order to exercise your rights under these limited warranties, the bicycle or frameset must be presented to an authorized Yeti dealer, together with proof of purchase.

- The above warranties have been in effect since January 2000. All Yeti frames sold prior to that date had a limited (1) one year warranty on the frameset.
- No Fault Replacement Policy
- Yeti Cycles will make replacement parts available at a minimum charge to the original owner in the event of a crash or any other non-warranty situation. Yeti Cycles does this at its sole discretion and reserves the right to refuse this offer.
- If you have a warranty concern, please contact your authorized Yeti dealer.

## **NO FAULT REPLACEMENT POLICY**

Yeti Cycles will make replacement parts available at a minimum charge to the original owner in the event of a crash or any other non-warranty situation. Yeti Cycles does this at its sole discretion and reserve the right to refuse this offer. If you have a warranty concern, please contact you authorized Yeti dealer.

## **PRODUCT LIFE CYCLE**

Every Yeti frameset has a useful product life cycle. The length of that useful product life cycle will vary depending on the construction and materials of the frameset, maintenance and care the frameset receives, and the amount and type of use the frameset is subjected to over its life. Yeti recommends that an authorized Yeti dealer should inspect the frame for stress annually. Frame stress could cause potential failure and the signs are usually apparent in the form of cracks, fracture lines, deformation, dents and other visual indicators of abnormality. These safety checks for frame stress are important to prevent accidents, injury to the cyclist and product failure of a Yeti frameset.

## **DISCLAIMER**

Yeti Cycles is not responsible for any damages to you or others arising from riding, transporting or other use of your bicycle. In the event that your frame breaks or malfunctions, Yeti Cycles shall have no liability or obligation beyond the repair or replacement of your frame pursuant to the terms outline in this warranty.

## **CONTACT INFO**

Yeti Cycles  
600 Corporate Circle, Unit D  
Golden, CO 80401  
(p) 303-278-6909  
(f) 303-278-6906  
[WWW.YETICYCLES.COM](http://WWW.YETICYCLES.COM)

## **BUSINESS HOURS**

Monday-Friday  
8AM-11:30AM, 1:00PM-5:30PM  
(Mountain Time)